

## EMBEDDED LF RFID READER M900 SERIES

### APPLICATIONS

- Asset Tracking
- Access Control
- Electronic Locks
- Personalization
- PC Log On

### FEATURES

- Short Range Applications
- 3.3 V Power Supply
- RFID LF: 125 + 134.2 kHz
- 10 cm Reading Range
- TTL Interface

### RFID OPTIONS

- **Read & Write:**  
Hitag-S 256, Hitag-S 2048,  
Hitag1
- **FDX-B:** ISO/IEC 11784/11785
- **Read Only:**  
EM4100, EM4200, TK4100

### PRODUCT DESCRIPTION

The iDTRONIC Embedded RFID LF Reader M900 is a small module for short range applications. Thanks to its tiny size and single-face laying components layout, it allows for embedding in various applications and devices. Especially for access control or asset tracking solutions, is this LF module applicable.

The LF module is available in 125 kHz or 134.2 kHz RFID LF Frequency range. It also supports read-only EM4100, EM4200, TK4100 and FDX-B. The LF Module can create ISO/IEC 11784/11785 from Hitag-S transponders. M900 LF supports all functions of the Hitag family. It achieves reading ranges of up to 10 cm (depending on type of transponder).

The embedded RFID LF reader M900 features one external antenna port. iDTRONIC Professional RFID offers a wide choice of antennas suitable for any purpose.

The Module M900 is available with an TTL interface. In low power mode, the M900 modules consumes less than 1 mA.

iDTRONIC's hardware comes with a useful SDK for the development of controller, Linux or Windows based applications. Beside the documentation, command protocols and source codes, the SDK includes a Windows based demo application with full functionality over all supported LF RFID standards.

## APPLICATION EXAMPLES

### ACCESS CONTROL



Due to its small dimensions and its wide-range of interfaces, the M890 module can be installed in all kinds of existing systems, locks, locking systems or devices.

Applications for personal or hotel card identification require a system that can authorize the right person for a specified access. The embedded module M900 can read these information reliably and securely. This increases security awareness against abusive and unauthorised access.

### ASSET TRACKING



Assets and small devices within working areas or workstations have to be organized properly. The LF Module Series offers the perfect solution for the application.

With its small dimensions and cutting edge microcontroller, it is embeddable in a wide range of tools or devices for production.

## TECHNICAL DATA

ELECTRICAL SPECIFICATIONS	
Power Supply	3.3 ... 5 Vdc
Power Consumption	< 45 mA
Operating Frequency	125 kHz + 134.2 kHz
Reading Distance	up to 10 cm*
Reader IC	Atmel Mega8A-MU
RF TX Speed	5.2 kbs
RF RX Speed	2, 4, 8 kbs
Antenna	External*
Antenna Inductivity	375 µH nominal value
Baudrate	9600...115200 bit/s, default: 9600 bit/s
Interface	UART TTL
PCB Connector	Soldering Pads (Suitable for SMD productions)

MECHANICAL SPECIFICATIONS	
Material	FR-4, Blue
Dimensions	25 × 16.5 × 2.8 mm
Weight	3 g
Mounting Options	Soldering

ENVIRONMENTAL CONDITIONS	
Operating Temperature	-20 °C ... +80 °C
Storage Temperature	-40 °C ... +85 °C
Humidity	up to 95 %, non condensing
MTBF	200'000 h

\*READING DISTANCE DEPENDS ON TAG, ANTENNA AND ENVIRONMENTAL CONDITIONS

SUPPORTED STANDARDS   TAGS	
Read-only	EM4100, EM4200, TK4100
Read   Write	Hitag-S 256, Hitag-S 2048, Hitag1
FDX-B	ISO/IEC 11784/11785

SDK INFORMATION	
Supported OS by Silabs USB VCP Driver	Windows 7/8/8.1/10 (v10.1.8) Windows 7/8/8.1/10 (v6.7.6) Windows XP/Server 2003 Vista/7/8/8.1 (v6.7) Windows 2K (v6.3a) WinCE (5.0, 6.0) Macintosh OSX (v5.2.4) Linux (3.x.x., 2.6.x) Android 4.2
Supported Languages	C++, Binary command protocol
Demo Software	Windows

FIRMWARE COMMANDS	
System	Get_VersionNum Buzzer Control LED Control Set Antenna
Read-Only Data Tags	Get UID
Hitag 1, Hitag S	Request Select Quiet ReadPage WritePage LockPage
FDX-B	Read FDX-B tag Format Hitag S tag into FDX-B tag Format Hitag S tag into ID tag

APPLICABLE STANDARDS	
EMC	EN 301489-1:2012-04 (v1.9.21) EN 301489-3:2013-12 (V1.6.1)
Radio Regulation	EN 300330-1:2015-08 (V1.8.1) EN 300330-2:2015-08 (V1.6.1)
Safety	EN 60950-1:2014-08 EN 62369-1:2010-03 EN 50364:2010-11
RoHS 2	EC Guideline 2011/65/EU
REACH	EC Guideline 2018/2005/EU
Certificates	FCC, CE

## MECHANICAL VIEW

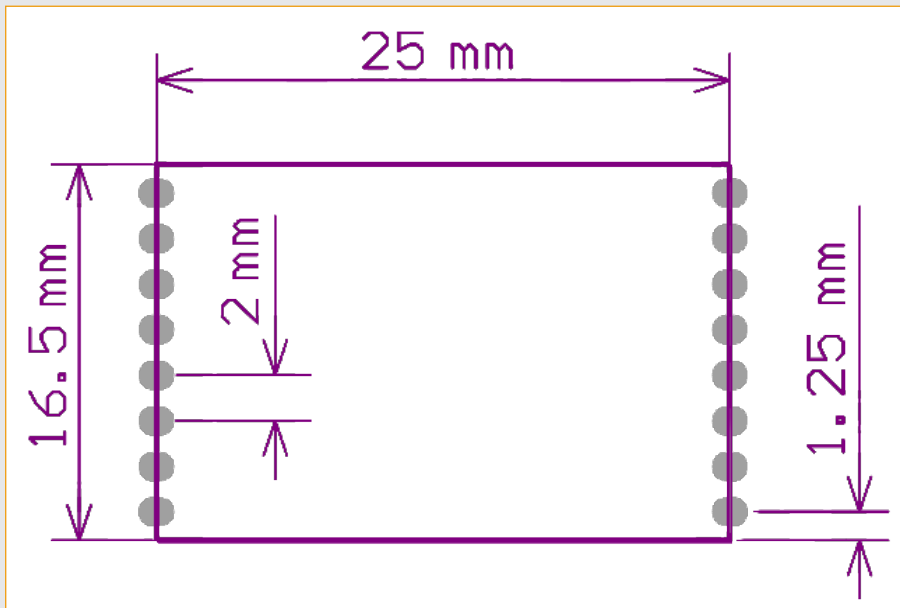

## PIN LAYOUT

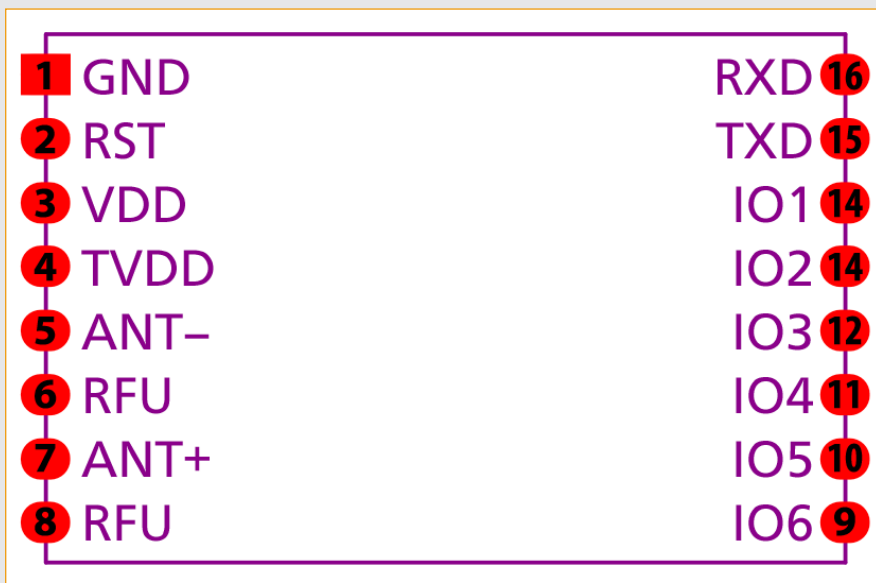

## CONNECTIONS

PIN	SIGNAL	IO TYPE	DESCRIPTION
1	GND	PWR	GND
2	RST	Input	Low power reset
3	VCC	PWR	DC 3.3 V
4	TV CC	PWR	3.3 ... 5 Vdc
5	ANT-	Output	Antenna –
6	NC	–	Do not connect
7	ANT +	Output	Antenna +
8	NC	–	Do not connect
9	IO6	Output	External LED
10	IO5	Output	External LED
11	IO4	Output	A group of IO used for control full color RGB light
12	IO3	Output	
13	IO2	Output	
14	IO1	Output	
15	TXD	Output	UART TX (TTL Level)
16	RXD	Input	UART RX (TTL Level)

## ORDER CODES

VERSIONS	ORDER CODES
OEM LF Module TTL: 125 kHz	OEM-LF-M900-TTL-125
OEM LF Module TTL: 134.2 kHz	On Request: MOQ – 50 Units

iDTRONIC GmbH  
 Ludwig-Reichling-Straße 4  
 67059 Ludwigshafen  
 GERMANY

Phone +49 (0) 621 66 90 09 4-0  
 Fax +49 (0) 621 66 90 09 4-9  
 E-Mail: info@idtronic-rfid.com  
 Web: idtronic-rfid.com

For further information & prices, please contact info@idtronic-rfid.com

Subject to alteration without prior notice  
 ©2021 iDTRONIC GmbH