

Vision Sensor

B50S102

Part Number

weQubeVision



- Image processing functions
- MultiCore technology

The vision sensor weQubeVision is based on the wenglor MultiCore technology. The functions autofocus, region of interest and tracking ensure optimal object detection. The following image processing modules are available: Dimensional accuracy check, sorting procedures, presence control, object counting, position output, pixel counting, filter options, and statistics evaluation.

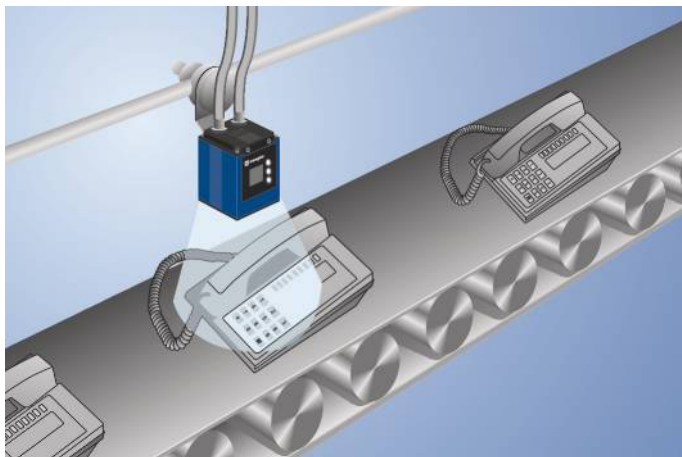

Technical Data

Optical Data	
Working Range	≥ 20 mm
Resolution	736 × 480 Pixel
Image Chip	monochrome
Light Source	Infrared Light
Service Life (T = +25 °C)	100000 h
Visual Field	see Table 1
Frame Rate	25 Hz

Electrical Data	
Supply Voltage	18...30 V DC
Current Consumption (U _b = 24 V)	< 200 mA
Response Time	40 ms
Temperature Range	0...40 °C
Inputs/Outputs	6
Switching Output Voltage Drop	< 2,5 V
Switching Output/Switching Current	100 mA
Short Circuit Protection	yes
Reverse Polarity Protection	yes
Interface	RS-232/Ethernet
Protection Class	III

Mechanical Data	
Setting Method	Ethernet
Housing Material	Aluminum
Degree of Protection	IP67
Connection	M12 × 1; 12-pin
Type of Connection Ethernet	M12 × 1; 8-pin

Function	
Presence Check	yes
Pixel Comparison	yes
Reference Image Comparison	yes
Tracking	yes
Object detection	yes
Dimensional accuracy check	yes

Web server	yes
Configurable as PNP/NPN/Push-Pull	●
Switchable to NC/NO	●
Illumination Output	●
RS-232 Interface	●
Ethernet	●
PROFINET	●
EtherNet/IP™	●
Connection Diagram No.	002 1008
Control Panel No.	X2
Suitable Connection Technology No.	50 87
Suitable Mounting Technology No.	560

Complementary Products

Disk with Polarizing Filter ZNNG004
Illumination Technology
Protection Housing ZNNS001, ZNNS002
weQube software DNNF001
weQubeDecode license upgrade DNNL002
weQubeOCR license upgrade DNNL003

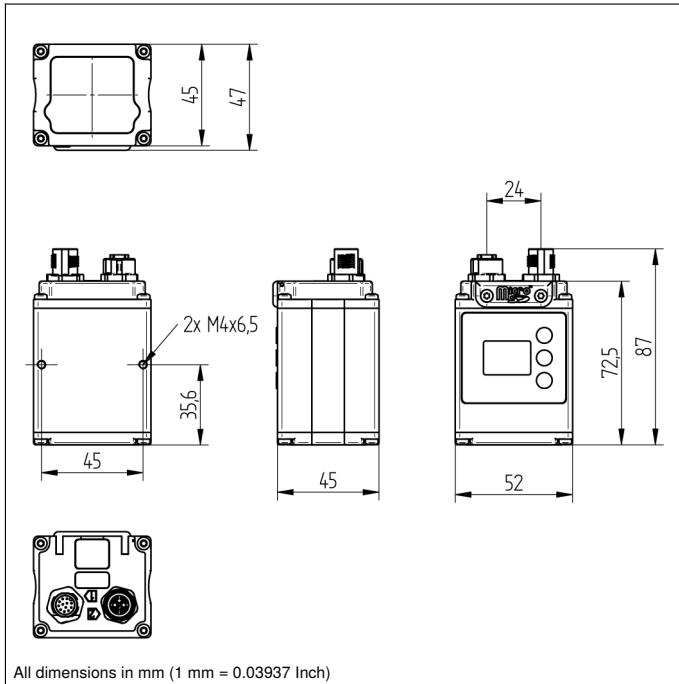

All dimensions in mm (1 mm = 0.03937 Inch)

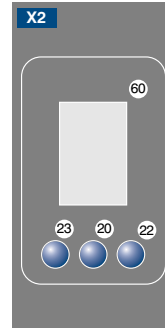
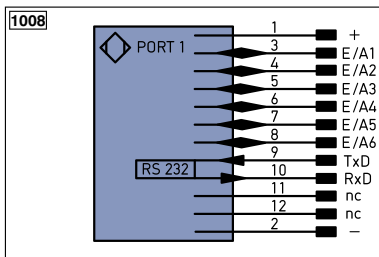
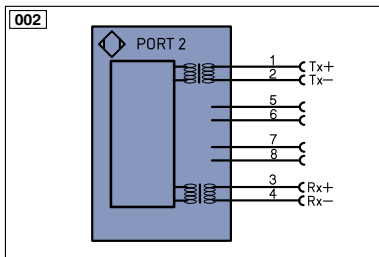
Ctrl. Panel

 20 = Enter Button
 22 = UP Button
 23 = Down Button
 60 = Display

Legend

+	Supply Voltage +	PT	Platinum measuring resistor	ENa	Encoder A
-	Supply Voltage 0 V	nc	not connected	ENb	Encoder B
~	Supply Voltage (AC Voltage)	U	Test Input	AMIN	Digital output MIN
A	Switching Output (NO)	U	Test Input inverted	AMAX	Digital output MAX
Ā	Switching Output (NC)	W	Trigger Input	AOK	Digital output OK
V	Contamination/Error Output (NO)	O	Analog Output	SY In	Synchronization In
ṽ	Contamination/Error Output (NC)	O-	Ground for the Analog Output	SY OUT	Synchronization OUT
E	Input (analog or digital)	BZ	Block Discharge	LI	Brightness output
T	Teach Input	AW	Valve Output	M	Maintenance
Z	Time Delay (activation)	a	Valve Control Output +		
S	Shielding	b	Valve Control Output 0 V		
RxD	Interface Receive Path	SY	Synchronization		
TxD	Interface Send Path	E+	Receiver-Line		
RDY	Ready	S+	Emitter-Line		
GND	Ground	≡	Grounding		
CL	Clock	SnR	Switching Distance Reduction		
E/A	Output/Input programmable	Rx+/-	Ethernet Receive Path		
IO-Link	IO-Link	Tx+/-	Ethernet Send Path		
PoE	Power over Ethernet	Bus	Interfaces-Bus A(+)/B(-)		
IN	Safety Input	La	Emitted Light disengageable		
OSSD	Safety Output	Mag	Magnet activation		
Signal	Signal Output	RES	Input confirmation		
Bl_D+/-	Ethernet Gigabit bidirect. data line (A-D)	EDM	Contactur Monitoring		
EN0_0542	Encoder 0-pulse 0-0 (TTL)	ENa_0542	Encoder A/Ā (TTL)		
		ENb_0542	Encoder B/B̄ (TTL)		

Wire Colors according to DIN IEC 757

BK	Black
BN	Brown
RD	Red
OG	Orange
YE	Yellow
GN	Green
BU	Blue
VT	Violet
GY	Grey
WH	White
PK	Pink
GNYE	Green/Yellow

Table 1

Working Distance	20 mm	200 mm	1000 mm
Visual Field	16 × 12 mm	120 × 90 mm	600 × 450 mm

